



Pinze cilindriche per mandrini a forte serraggio
Bushes for high power milling chucks
Zwischenbuchsen für Hochleistungfutter
Douilles pour mandrins à grand puissance de serrage

Pag. - Seite

1



Pinze cilindriche per mandrini a forte serraggio
Bushes for high power milling chucks
Zwischenbuchsen für Hochleistungfutter
Douilles pour mandrins à grand puissance de serrage

Pag. - Seite

2



Pinze cilindriche per mandrini idraulici
Bushes for Hydraulic expansions chucks
Reduzierhulsen für Hydrodehnspannfutter
Douilles pour mandrins expansible hydrauliques

Pag. - Seite

3



Pinze cilindriche per mandrini idraulici
Bushes for Hydraulic expansions chucks
Reduzierhulsen für Hydrodehnspannfutter
Douilles pour mandrins expansible hydrauliques

Pag. - Seite

4

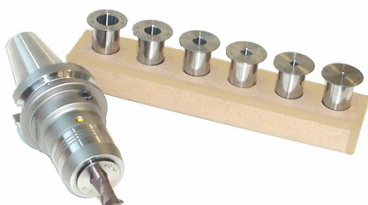

Serie di pinze cilindriche
Bushes set
Geschlitzte Zwischenbuchsen Satz
Jeux de douilles

Pag. - Seite

5



Bussole portamaschi per mandrini tipo Weldon
Tap Sleeves for End Mill Holders
Gewindebohrer-Spannhülse
Douilles de Serrage pour Mandrins type Weldon

Pag. - Seite

6

6 Bushings



Pinze cilindriche per mandrini a forte serraggio
Bushes for high power milling chucks
 Zwischenbuchsen für Hochleistungfutter
Douilles pour mandrins à grand puissance de serrage

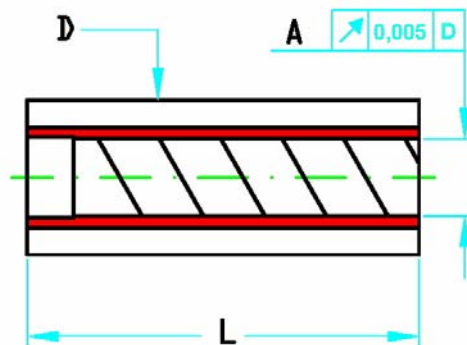
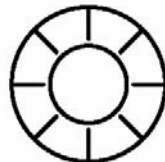

- Passaggio del refrigerante dai tagli
- With peripheral cooling
- Mit Peripheriekühlung
- Avec refroidissement périphérique

Ref.	Order Nr.	☺	D	L	Price
188-000	SCK20.A6	•	20	50,5	
	SCK20.A7	•	20	50,5	
	SCK20.A8	•	20	50,5	
	SCK20.A9	•	20	50,5	
	SCK20.A10	•	20	50,5	
	SCK20.A11	•	20	50,5	
	SCK20.A12	•	20	50,5	
	SCK20.A13	•	20	50,5	
	SCK20.A14	•	20	50,5	
	SCK20.A15	•	20	50,5	
	SCK20.A16	•	20	50,5	

Ref.	Order Nr.	☺	D	L	Price
188-000	SCK32.A6	•	32	60,5	
	SCK32.A8	•	32	60,5	
	SCK32.A10	•	32	60,5	
	SCK32.A12	•	32	60,5	
	SCK32.A14	•	32	60,5	
	SCK32.A16	•	32	60,5	
	SCK32.A18	•	32	60,5	
	SCK32.A20	•	32	60,5	
	SCK32.A22	•	32	60,5	
	SCK32.A25	•	32	60,5	

- ☹ • Per utensili con gambo in tolleranza h6 / For tool shank tolerance h6
- ☹ • Für Werkzeugshafttolerance h6 / Pour une tolerance de queue d'outil h6

Estrattore per pinze cilindriche SCK
SCK-Bushes extractor
 SCK Buchsenzieher
Poignée d'extraction pour douilles SCK

Ref.	Order Nr.	Price
188-001	SCK - EX	

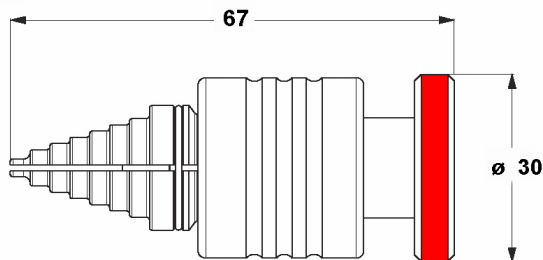

① Adatte per mandrini SINO-T e SINO-R prodotti dalla Firma SCHUNK GmbH & Co. KG / D-74348 Lauffen
Suitable for SINO-T and SINO-R chucks produced by SCHUNK
 Passend für SCHUNK-Spannfutter SINO-T und SINO-R
Adaptée à les mandrins SCHUNK Model SINO-T et SINO-R

6 Bushings

CAPORALI

Pinze cilindriche per mandrini a forte serraggio
 Bushes for high power milling chucks
 Zwischenbuchsen für Hochleistungsfutter
 Douilles pour mandrins à grand puissance de serrage

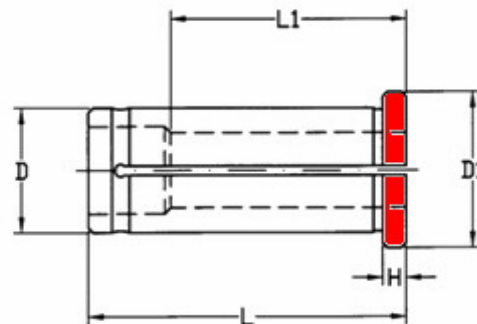
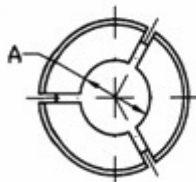

Ref.	Order Nr.	☹	D	D1	L	L1	H	Price
188-003	3SR20.A3	•	20	25	54	15	4	
	3SR20.A4	•	20	25	54	23	4	
	3SR20.A5	•	20	25	54	23	4	
	3SR20.A6	•	20	25	54	35	4	
	3SR20.A7	•	20	25	54	35	4	
	3SR20.A8	•	20	25	54	40	4	
	3SR20.A9	•	20	25	54	40	4	
	3SR20.A10	•	20	25	54	40	4	
	3SR20.A11	•	20	25	54	40	4	
	3SR20.A12	•	20	25	54	40	4	
	3SR20.A13	•	20	25	54	45	4	
	3SR20.A14	•	20	25	54	45	4	
	3SR20.A15	•	20	25	54	45	4	
	3SR20.A16	•	20	25	54	45	4	

- ☹ • Per utensili con gambo in tolleranza h6 / For tool shank tolerance h6
- ☹ • Für Werkzeugshafttolerance h6 / Pour une tolerance de queue d'outil h6

ALTISSIMA PRECISIONE DIMENSIONALE E DI CONCENTRICITA'

- precisione di concentricità
- t.l.r. accuracy
- rundlaufgenauigkeit
- précision de concentricité

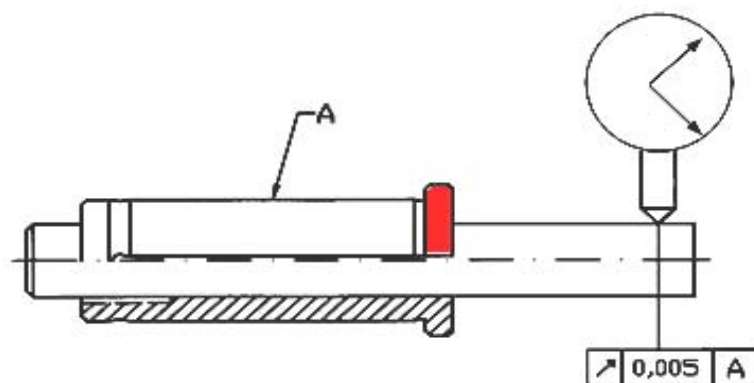

6 Bushings



Pinze cilindriche per mandrini idraulici
 Bushes for Hydraulic expansions chucks
 Reduzierhulsen für Hydrodehnspannfutter
 Douilles pour mandrins expansible hydrauliques

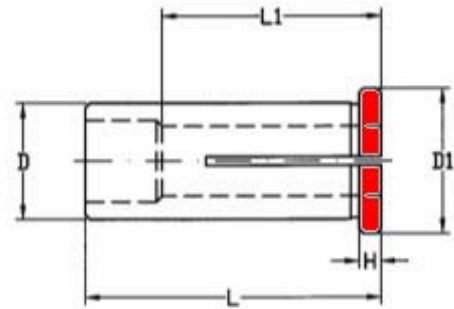

- A tenuta meccanica del liquido refrigerante
- Kuhlmitteldicht max 60 Bar
- Mechanical sealed for high pressure coolant flow
- Étanches au liquide de arrosage

Ref.	Order Nr.	☺	D	D1	L	L1	H	€
188-005	4SR12.A3	•	12	16	46	15	2	
	4SR12.A4	•	12	16	46	23	2	
	4SR12.A5	•	12	16	46	23	2	
	4SR12.A6	•	12	16	46	35	2	
	4SR12.A8	•	12	16	46	40	2	

Ref.	Order Nr.	☺	D	D1	L	L1	H	€
188-005	4SR20.A3	•	20	25	54	15	4	
	4SR20.A4	•	20	25	54	23	4	
	4SR20.A5	•	20	25	54	23	4	
	4SR20.A6	•	20	25	54	35	4	
	4SR20.A7	•	20	25	54	35	4	
	4SR20.A8	•	20	25	54	40	4	
	4SR20.A9	•	20	25	54	40	4	
	4SR20.A10	•	20	25	54	40	4	
	4SR20.A11	•	20	25	54	40	4	
	4SR20.A12	•	20	25	54	40	4	
	4SR20.A13	•	20	25	54	45	4	
	4SR20.A14	•	20	25	54	45	4	
	4SR20.A15	•	20	25	54	45	4	
	4SR20.A16	•	20	25	54	45	4	

Ref.	Order Nr.	☺	D	D1	L	L1	H	€
188-005	4SR32.A6	•	32	36	60	35	4	
	4SR32.A8	•	32	36	60	40	4	
	4SR32.A10	•	32	36	60	40	4	
	4SR32.A12	•	32	36	60	40	4	
	4SR32.A14	•	32	36	60	45	4	
	4SR32.A16	•	32	36	60	48	4	
	4SR32.A18	•	32	36	60	48	4	
	4SR32.A20	•	32	36	60	50	4	
	4SR32.A25	•	32	36	60	56	4	

- ☺ Per utensili con gambo in tolleranza h6
- ☺ For tool shank tolerance h6
- ☺ Für Werkzeugshafttolerance h6
- ☺ Pour une tolerance de queue d'outil h6

- ① Adatte anche per mandrini a forte serraggio
- ① Suitable for power milling chucks

- precisione di concentricità
- t.i.r. accuracy
- rundlaufgenauigkeit
- précision de concentricité

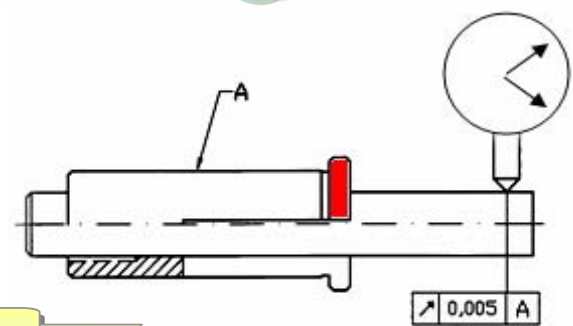

6 Bushings



Pinze cilindriche per mandrini idraulici
Bushes for Hydraulic expansions chucks
 Reduzierhulsen für Hydrodehnspannfutter
Douilles pour mandrins expansible hydrauliques

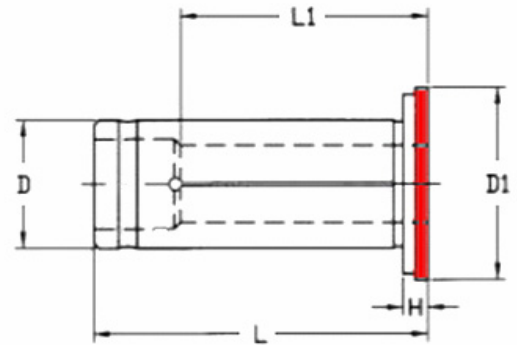
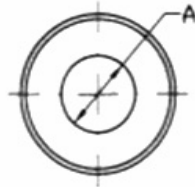
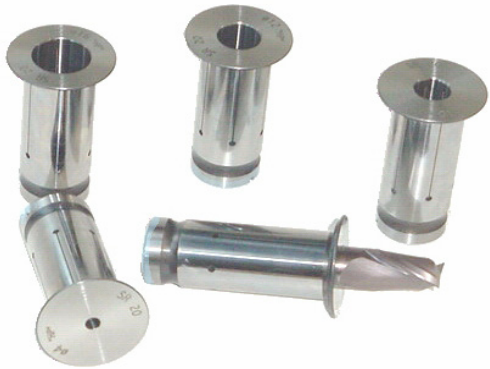

- A tenuta meccanica del liquido refrigerante
- Kuhlmitteldicht max 60 Bar
- Mechanical sealed for high pressure coolant flow
- Étanches au liquide de arrosage

Ref.	Order Nr.	☺	D	D1	L	H	Price
188-007	SR20.A3	•	20	30	52,5	2	
	SR20.A4	•	20	30	52,5	2	
	SR20.A5	•	20	30	52,5	2	
	SR20.A6	•	20	30	52,5	2	
	SR20.A7	•	20	30	52,5	2	
	SR20.A8	•	20	30	52,5	2	
	SR20.A9	•	20	30	52,5	2	
	SR20.A10	•	20	30	52,5	2	
	SR20.A11	•	20	30	52,5	2	
	SR20.A12	•	20	30	52,5	2	
	SR20.A13	•	20	30	52,5	2	
	SR20.A14	•	20	30	52,5	2	
	SR20.A15	•	20	30	52,5	2	
	SR20.A16	•	20	30	52,5	2	

- ☺
- Per utensili con gambo in tolleranza h6
- For tool shank tolerance h6
- Für Werkzeugshafttolerance h6
- Pour une tolerance de queue d'outil h6



- precisione di concentricità
- t.i.r. accuracy
- rundlaufgenaukelt
- précision de concentricité

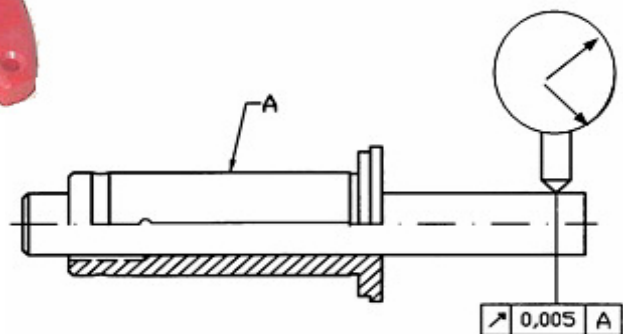

6 Bushings

Serie di pinze cilindriche
Bushes set
 Geschlitzte Zwischenbuchsen Satz
Jeux de douilles



Ref.	Order Nr.	Pinze nella serie <i>Collets in the set</i>	Price
188-110	SCK20-6	A. 6 . 8 . 10 A. 12 . 14 . 16	
	SCK32-7	A. 6 . 8 . 10 . 12 A. 16 . 20 . 25	



Ref.	Order Nr.	Pinze nella serie <i>Collets in the set</i>	Price
188-112	3SR20-6	A. 6 . 8 . 10 A. 12 . 14 . 16	



Ref.	Order Nr.	Pinze nella serie <i>Collets in the set</i>	Price
188-114	4SR12-5	A. 3 . 4 . 5 . 6 . 8	
	4SR20-6	A. 6 . 8 . 10 A. 12 . 14 . 16	
	4SR32-7	A. 6 . 8 . 10 . 12 A. 16 . 20 . 25	

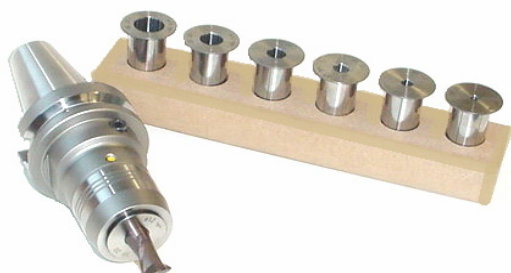

Ref.	Order Nr.	Pinze nella serie <i>Collets in the set</i>	Price
188-116	SR20-6	A. 6 . 8 . 10 A. 12 . 14 . 16	

6 Bushings



Bussole portamaschi per mandrini tipo Weldon
 Tap Sleeves for End Mill Holders
 Gewindebohrer-Spannhülse
 Douilles de Serrage pour Mandrins type Weldon

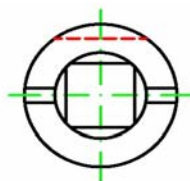
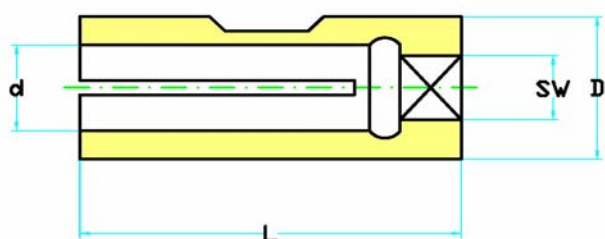

Ref.	Order Nr.	D	d x SW	L	Price
188-030	TSW10.035	10	3,5 x 2,7	40	
	TSW10.040	10	4 x 3	40	
	TSW10.045	10	4,5 x 3,4	40	
	TSW12.060	12	6 x 4,9	45	
	TSW14.070	14	7 x 5,5	45	
	TSW14.080	14	8 x 6,2	48	
	TSW16.090	16	9 x 7	48	
	TSW16.100	16	10 x 8	48	
	TSW18.110	18	11 x 9	50	
	TSW20.120	20	12 x 9	50	
	TSW25.140	25	14 x 11	56	
	TSW25.160	25	16 x 12	56	
	TSW32.180	32	18 x 14,5	60	
	TSW32.200	32	20 x 16	60	
	TSW32.220	32	22 x 18	60	